



AIR CLEANERS/FILTERS

TPD Technical
Publications
Litho U.S.A.

505,132M
4/2014
Supersedes 10/2009

HEALTHY CLIMATE® MEDIA AIR CLEANER

INSTALLATION INSTRUCTIONS AND HOMEOWNERS MANUAL FOR HEALTHY CLIMATE® CABINET MODELS HCC14-23, HCC16-28 AND HCC20-28

General

The Healthy Climate® Media Air Cleaner uses an electrostatically charged media to strain airborne particles as small as 0.3 microns with an efficiency rating of 95% or more (MERV 16). Unlike other high efficiency (MERV 16) air cleaners, the Media Air Cleaner uses no energy to operate.

The Healthy Climate® cabinet is shipped compact, and requires minimal assembly. The Cabinet can be installed on the furnace/air handler horizontally, or vertically, at the top, or at the bottom, depending on the application (see Page 4 for application diagrams). Healthy Climate® Media Filter will last up to one year (MERV 16 and MERV 11) depending on conditions in the home. The cabinet is designed to house the HCF14-11, HCF14-16, HCF16-11, HCF16-16, HCF20-11, HCF20-16 box media filter purchased separately.

⚠ WARNING

Risk of property damage, injury, or death.

Installation, adjustments, alterations, service and maintenance must be performed by a Lennox dealer.

⚠ CAUTION

Sharp Edges Hazard.

Equipment sharp edges can cause injuries.

Use protective gloves when grasping equipment edges.

⚠ CAUTION

Risk of equipment damage and/or high energy usage.

Dirty air filters will cause high energy usage and/or damage to the ventilation system.

Replace filters at recommended intervals.

Shipping and Packing List

Package 1 of 1 contains:

- 2 - Side panels
- 2 - Side rails
- 1 - Front panel
- 1 - Rear panel
- 1 - Door
- 8 - #8 screws
- 1 - Installation instructions
- 1 - Lennox logo label
- 1 - Warranty sheet

Required Tools

The following tools are required to attach the filter cabinet to the furnace/air handler:

- Electric drill
- 1/4" (6mm) hex head tool
- Tin snips
- Screwdriver
- Rule/tape measure
- Gloves for sharp edge protection
- Foil tape

Rules for Safe Installation

1. Read this Owners Manual and Rules for Safe Operation carefully. Failure to follow these rules and instructions could cause a malfunction of filter or unsatisfactory service.
2. Follow a regular service and maintenance schedule for efficient operation.
3. Maximum static weight for cabinet - 400 lbs. (181 kg.)



0414

505132M

Dimensions/Specifications

Dimensions - inches (mm)					
Model #	X	Y	Y1	Z	Z1
HCC14-23	7 (179)	21-1/4 (540)	18-3/4 (476)	23 (584)	18-1/2 (470)
HCC16-28	7 (179)	17-1/4 (438)	14-3/4 (375)	28-1/2 (724)	24 (610)
HCC20-28	7 (179)	21 (533)	18-1/2 (470)	28-1/2 (724)	24 (610)

Specifications subject to change without notice.

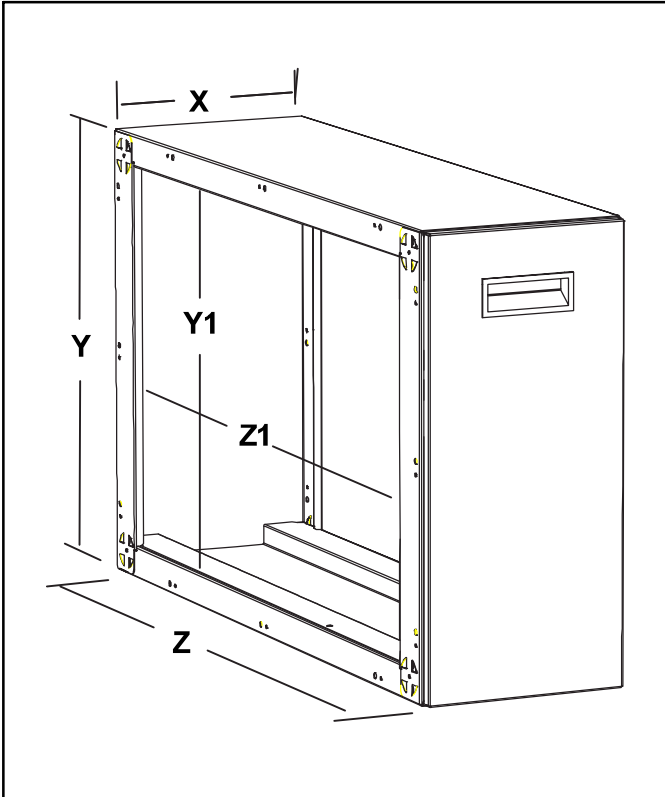

Figure 1. Dimensions

Unpacking

The cabinet must be unpacked and assembled prior to use. Refer to figure 2 to ensure all the necessary components are included before assembling.

Component List

- A 1 - Rear Frame
- B 1 - Front Frame
- C 1 - Door
- D 2 - Side Rail
- E 2 - Side Panel

NOTE - The front frame B and door C are shipped attached.

Unpacking Required

⚠ CAUTION

Sharp Edges Hazard.

Equipment sharp edges can cause injuries.

Use protective gloves when grasping equipment edges.

1. Remove all protective packing material from the cabinet.
2. All packing material should be properly discarded.
3. Side rails (D) are attached to the filter cabinet after the filter cabinet is installed on the Furnace/Air Handler.

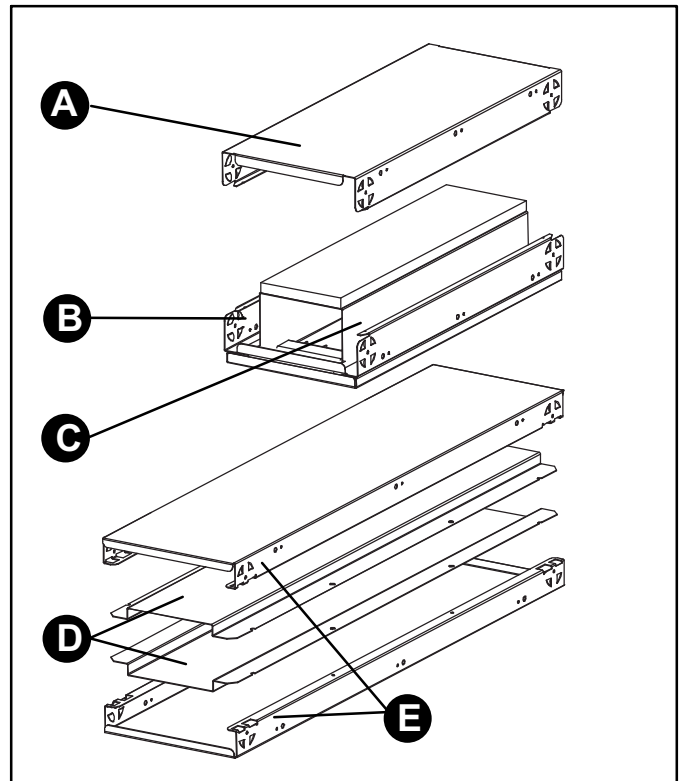

Figure 2. Unpack

Assembly

Assembling the Cabinet

The cabinet sections are designed to lock together. Align the edges as shown in figure 3. It may be necessary to apply force to snap the tight pieces together.

1. Remove front frame B from door C.
2. Place side panel E on a firm surface. Align and insert front frame B into one end of side panel E (see figure 3). Firmly press down until each corner has snapped into place.

3. Align and insert rear frame A into side panel E (see figure 4).
4. Align and insert remaining side panel E into front frame B and rear frame A. Firmly press down until each corner has snapped into place (see figure 5).

NOTE: Side rails (D) are attached to the cabinet after the cabinet is installed on the Furnace/Air Handler (see figure 13).

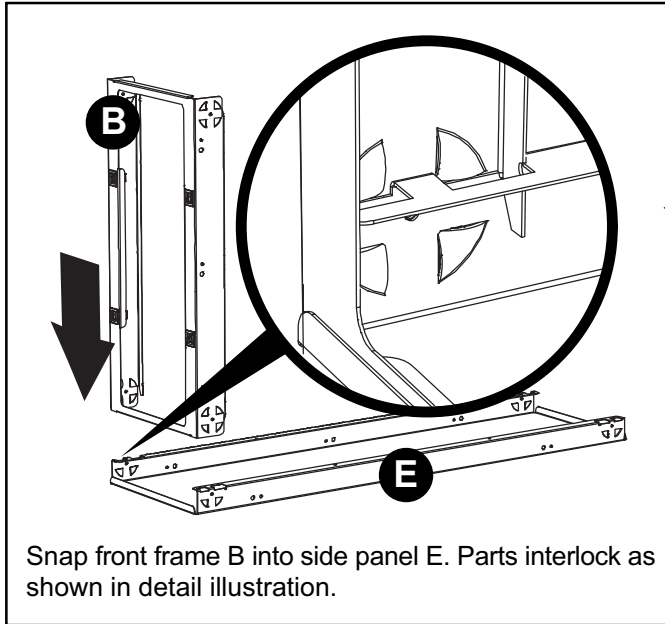

Snap front frame B into side panel E. Parts interlock as shown in detail illustration.

Figure 3. Assemble Front Frame (B) to Side Panel (E)

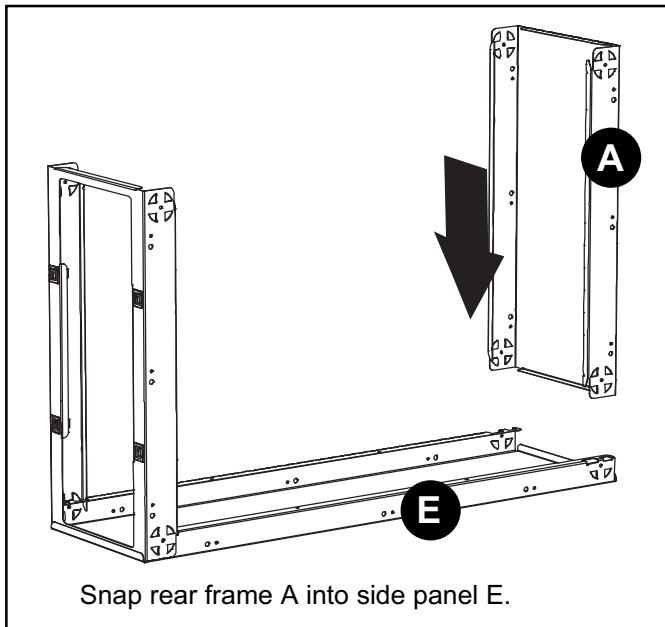

Snap rear frame A into side panel E.

Figure 4. Assemble Rear Frame (A) to Side Panel (E)

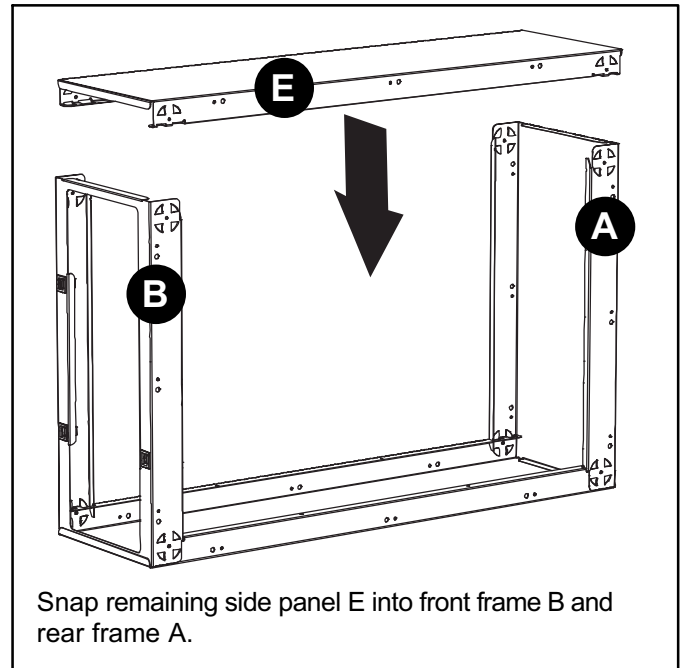

Snap remaining side panel E into front frame B and rear frame A.

Figure 5. Assemble Remaining Side Panel (E)

Applications

Up-flow Furnace/Air Handler

Cabinet is installed horizontally beneath the furnace/air handler. Return air enters from the bottom (see figure 6).

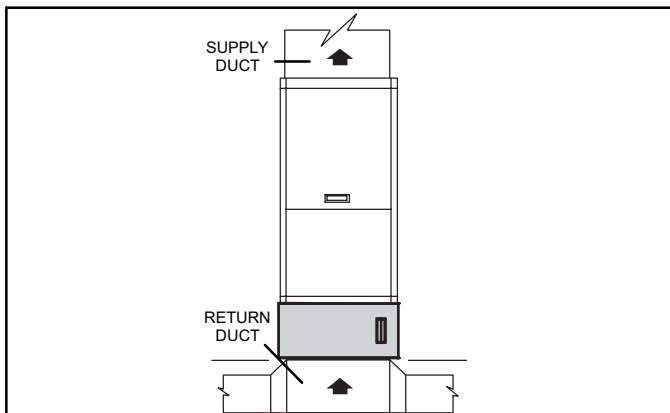

Figure 6. Up-flow Furnace/Air Handler

Down-flow Furnace/Air Handler

Cabinet is installed horizontally in the return air duct just above the furnace/air handler (see figure 7).

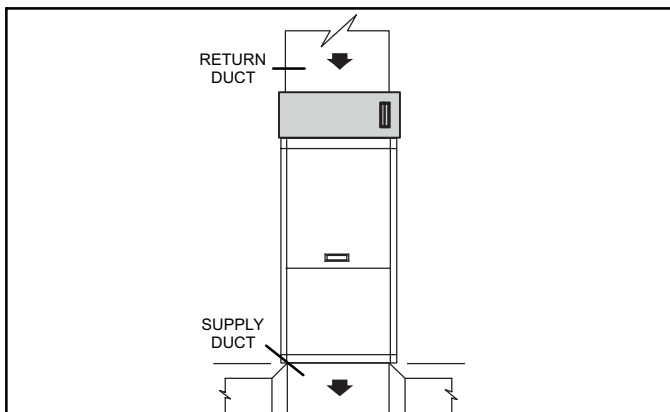

Figure 7. Down-flow Furnace/Air Handler

Up-flow Furnace (up to 4 ton application)

Cabinet is installed vertically and return air enters the furnace side inlet (see figure 8).

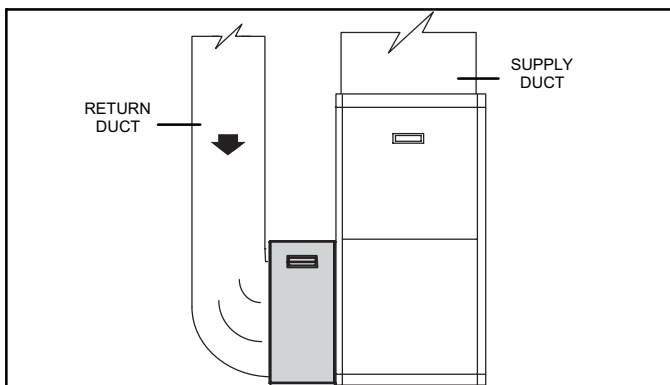

Figure 8. Up-flow Furnace (up to 4 ton)

Up-flow Furnace (5-ton application)

Option 1—Install Return air base, part numbers 98M60, 98M58. HCC20-28 Cabinet is installed vertically and return air enters the furnace side inlet (see figure 9).

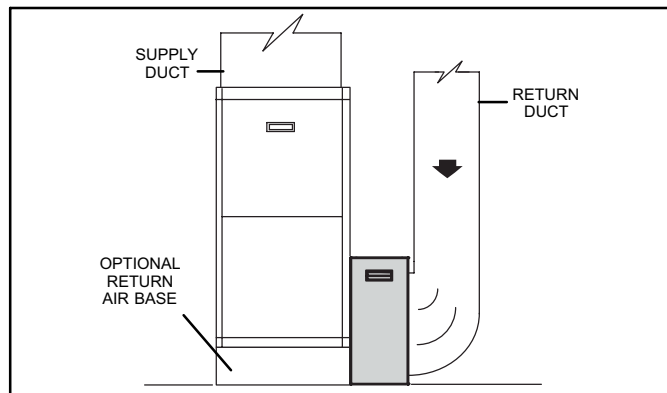

Figure 9. Up-flow Furnace (5 ton, Option 1)

Option 2—Over cut top edge of side return opening by 1" to 15" x 23". HCC20-28 Cabinet is installed vertically and return air enters the furnace side inlet (see figure 10).

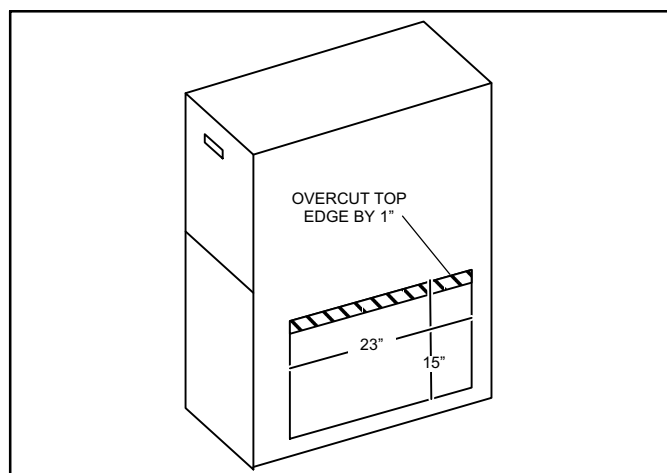

Figure 10. Up-flow Furnace (5 ton, Option 2)

Horizontal Furnace/Air Handler

Cabinet is installed vertically in the return air duct near the furnace/air handler (see figure 11).

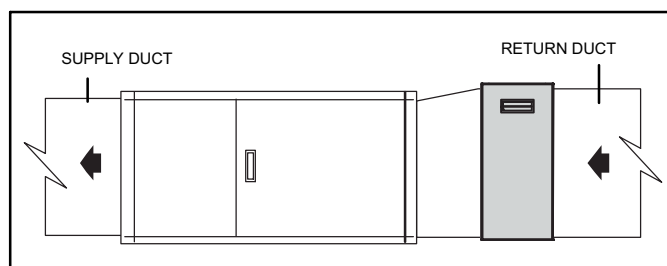

Figure 11. Horizontal Furnace/Air Handler

Installation

⚠️ WARNING

Risk of property damage, injury, or death.

Installation, adjustments, alterations, service and maintenance must be performed by a Lennox dealer.

Cabinet Installation

The following is a typical installation of the cabinet with an up-flow furnace (see figure 8).

1. Position the cabinet alongside the furnace with the access door opening facing outward.
2. Align the cabinet opening with the opening on the furnace. (For 5 ton application, use option 1 or 2 [figure 9 or 10]).
3. Secure the cabinet to the furnace using sheet metal screws in the pre-drilled cabinet mounting holes (see figure 12).
4. Use a butt joint to attach the duct to the upstream side of the cabinet.

NOTE - If necessary, use sheet metal turning vanes to improve air movement through an elbow in the duct.

5. Connect the next section of the duct. If necessary, use a properly sized wooden block to support a duct elbow.
6. Use foil tape to seal all duct joints. This prevents dust from entering the air stream.
7. Insert side rails (D) into the cabinet and use the provided screws to secure them to the cabinet at both the top and bottom (see figure 13).
8. Slide the filter into the rail and secure the cabinet door (see figure 14).

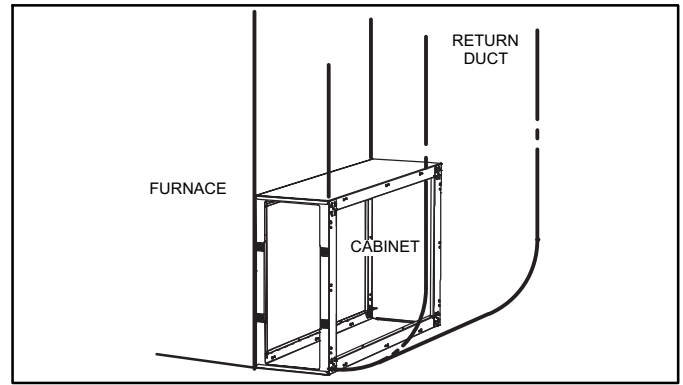

Figure 12. Attach Cabinet to Furnace and Duct

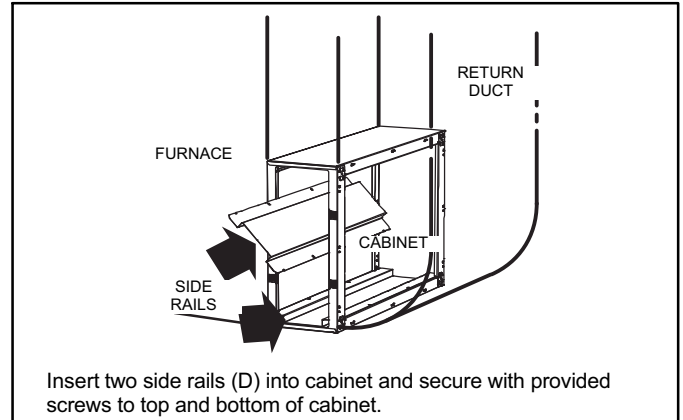

Figure 13. Install Side Rails

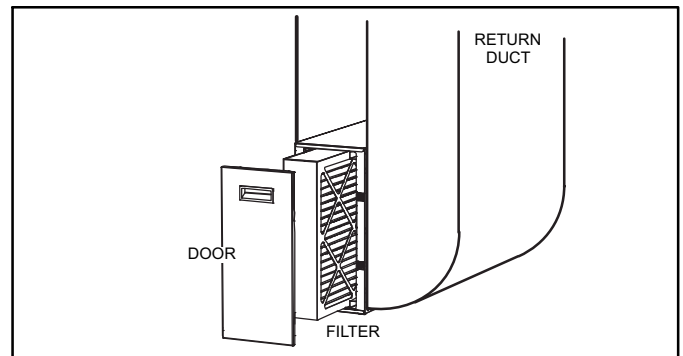

Figure 14. Insert Filter and Attach Door

⚠ WARNING	
	Risk of Carbon Monoxide poisoning. Can cause injury or death.
	Do not operate without Filter Cabinet door in place. Operation of this equipment without the Filter Cabinet door in place may cause exhaust fumes to be drawn into occupied spaces.

